

E205 Long Range Wireless Modem V1.0 Data Sheet



The Long Range Wireless Modem **E205** is a radio transmitter / receiver designed for transparent wireless data transmission over long distances. It operates in the frequency range between 419 MHz and 439 MHz at a fixed data rate of 4,800 baud. **E205** features a RS232 data interface with RTS / CTS handshake. The transmission power of the unit is adjustable in 3 steps up to 5 watts and its receiving sensitivity is very high. Depending on the connected external antenna (not included), a transmission range of up to 100 km can be reached with **E205**.

Absolute Maximum Ratings

Parameters	Characteristics		Unit	Note
	min.	max.		
Operating supply voltage (VCC)	-0.3	20.0	V	
Input Voltage CHANNEL SELECT	-0.3	VCC	V	CS0, CS1, CS2
Input Voltage DTR_PGM	-0.3	16.0	V	
Input Voltage RXD, RTS	-20.0	20.0	V	

Features

Parameters	Characteristics			Unit	Note
	min.	typ.	max.		
Operating supply voltage (VCC)	11.5	15.0	16.0	V	
Operating temperature	-30		70	°C	For ambient temperature in operation, see data for transmission duty cycle as well as safety notes table
Storage temperature	-30		70	°C	
Length			116.5	mm	Without adapter plate
			121.3	mm	With adapter plate
Width			78.3	mm	
Height			55.3	mm	Without adapter plate
			57.0	mm	With adapter plate
Adapter plate width		74.0		mm	
Adapter plate height		1.5		mm	
Vibration			5	g _n	Tested for 1 hour along 3 spatial axes in the frequency range between 5 Hz and 2000 Hz (DIN EN 60068-2-6:2008)
Shock			30	g _n	Tested with pulse duration of 11ms, 3 pulses along 3 spatial axes (DIN EN 60068-2-27:2010)
Reliability (MTBF)		75,000		hours	MIL-HDBK-217F N2 ambient temperature: 50°C
Storage lifetime	5			years	
Weight			370	g	

Parameters	Characteristics			Unit	Note
	min.	typ.	max.		
Frequency	419.0		439.0	MHz	Configurable (see configuration table)
Frequency step	1			kHz	
Transmission power			0.5	W	With minimum transmission power, within operating voltage range, 50Ω
	1.8	2.0	2.2	W	With transmission power of 2 W, within operating voltage range, 50Ω
	4.5	5.0	5.5	W	With transmission power of 5 W, within operating voltage range, 50Ω
Receiving sensitivity		-109		dBm	Within operating temperature range 50Ω, 10 ⁻⁴ BER
		-114		dBm	at 25°C, 50Ω, 10 ⁻⁴ BER
Input level			+10	dBm	Receiving, 50Ω
Current consumption when receiving	170	220	250	mA	Variation of < 1% within operating temperature and voltage range
Current consumption when transmitting			1.45	A	With transmission power of 2 W, 25°C and 15,0 V
			1.60	A	With transmission power of 5 W, 25°C and 15,0 V
Channel bandwidth			25	kHz	Within operating temperature and voltage range, -36 dBc bandwidth
Transmission DutyCycle			100	%	Max. ambient temperature: 50°C
			50	%	Refers to 1 minute, max. Ambient temperature: 70°C
Max. transmission time (Transmit Watchdog)			30	s	After max. transmission time automatic reset to receiving mode, function can be disabled, see configuration table
Data rate RS-232		4,800		baud	Tolerance ±5%, data format 8N1, in normal operation mode
		4,800		baud	Tolerance ±5%, data format 8N1, in configuration mode
Switch-on delay			5	s	Operating voltage supply until unit is ready for operation
Switch-over time from transmission to reception mode			40	ms	After RTS signal changes from active to inactive, see configuration and data interface table
Switch-over time from reception to transmission mode			1	ms	With RTS/CTS delay time = 0 ms
RTS/CTS delay time in transmission mode	0		30	ms	Configurable, see configuration table
Data processing time in transmission mode		15		ms	See data interface table

Dimensioned Drawing

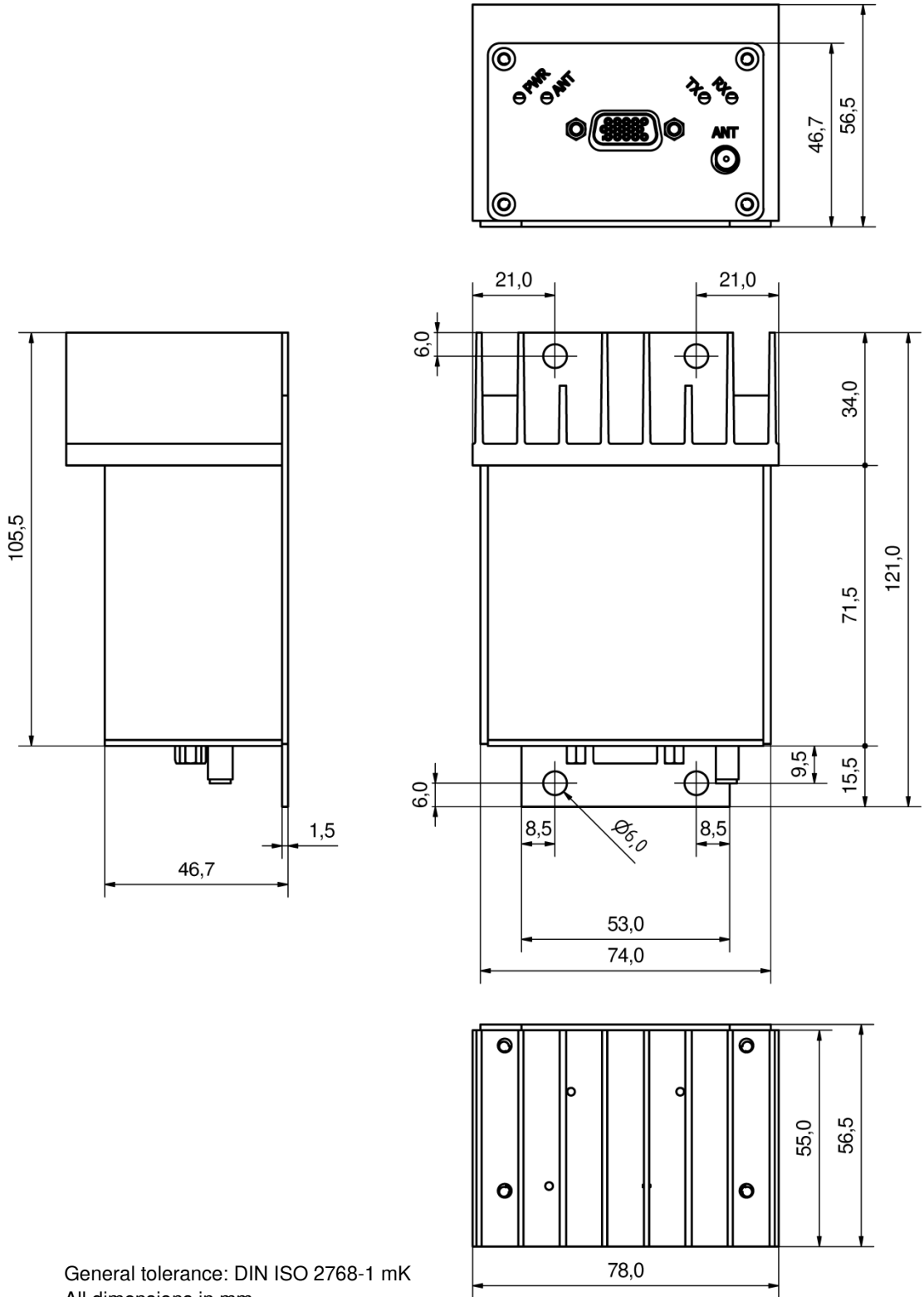

General tolerance: DIN ISO 2768-1 mK
All dimensions in mm

Connections and Indication

Data interface	RS-232, 15 pin D-SUB socket ("HD15"), configured as DCE connection to a DTE or Windows PC via special cable (accessory)
ANT interface	Antenna connection, SMA socket (SMA(f)), 50 Ω
RX LED (yellow)	Reception mode (RX) Lights when incoming data is present (DCD active, see Data Interface Table)
TX LED (red)	Transmission mode (TX) Lights when the modem is in transmission mode
PWR LED (green)	Lights continuously when the modem is powered up Flashes when modem is in configuration mode
ANT LED (blue)	Lights continuously with correctly connected antenna Flashes if no antenna connected or connected incorrectly The antenna check is carried out when the operating voltage is applied and in the normal operation mode only. As long as the ANT LED is flashing, no communication is possible.

Connecting Cable

The communication between **E205** and a connected device is performed via a special cable in both normal and configuration mode.

Pin assignment:

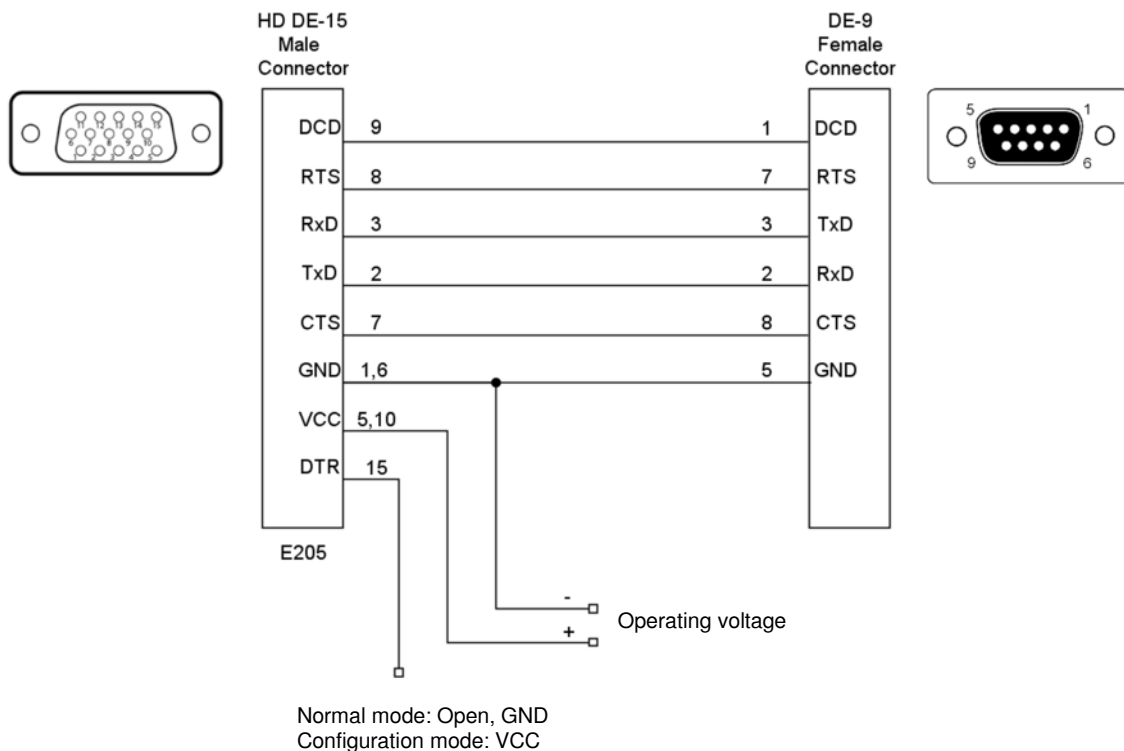

Data Interface

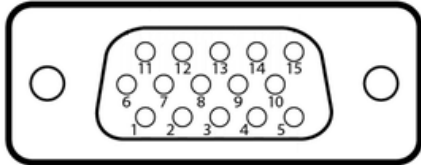

As seen from the modem (towards the cable connector):

- I = Input
- O = Output
- P= Power

EIA standard:

- voltage from -3 V to -15 V: logical one / inactive
- voltage from +3 V to +15 V: logical zero / active
- voltage from -3 V to +3 V: undefined

Pin	Name	Description	Type	Level	Unit	Note
1	GND	Ground (reference potential)	P	0	V	
2	RxD	Reception Data	O	EIA standard	V	
3	TxD	Transmission Data	I	EIA standard	V	
4	-	Not used				This pin should be left unconnected
5	VCC	Operating supply voltage	P	11.5 - 16.0	V	See features table
6	GND	Reference potential	P	0	V	
7	CTS	Clear To Send	O	EIA standard	V	Clear for transmission
8	RTS	Request To Send	I	EIA standard	V	Request for transmission
9	DCD	Data Carrier Detect	O	EIA standard	V	Detection of incoming data
10	VCC	Operating supply voltage	P	11.5 – 16.0	V	See features table
11	CS0	Channel Selection	I	0 or open	V	Internal pull-ups; See configuration table
12	CS1	Channel Selection	I	0 or open	V	
13	CS2	Channel Selection	I	0 or open	V	
14	-	Not used				This pin should be left unconnected
15	DTR_PGM	Configuration	I	0 or VCC	V	See configuration table

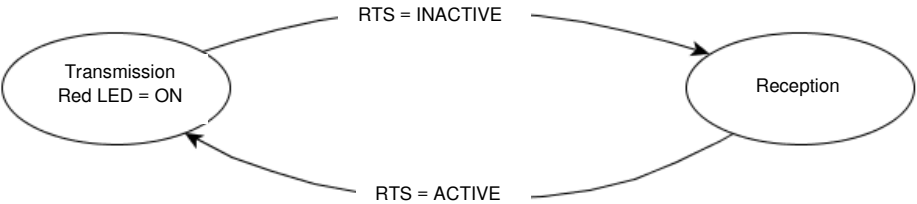
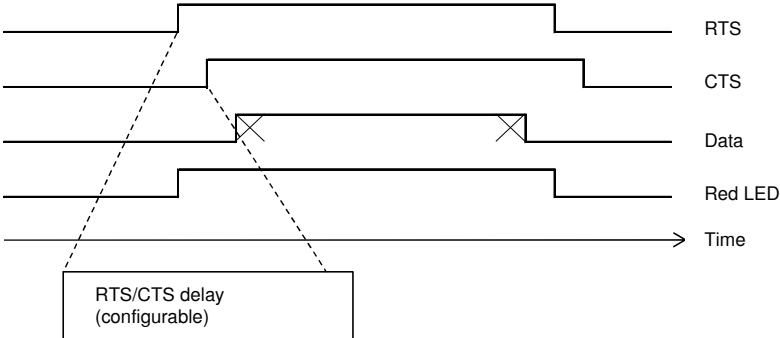
Operating Modes	
Operating Mode	Description
Normal operation	<p>Switching to this operating mode:</p> <ul style="list-style-type: none"> - When operating voltage is applied - DTR_PGM = 0 or open <p>Indication:</p> <ul style="list-style-type: none"> - green PWR LED lights <p>RS-232 interface:</p> <ul style="list-style-type: none"> - RS232, 4.800 baud, 8N1 - RTS/CTS handshake <p>Mode of operation:</p> <p>By default the unit operates in reception mode and switches over to transmission mode when RTS = active. Except for this, there are no further status conditions in normal operation.</p>  <p>Once RTS = ACTIVE, the unit switches over to transmission mode immediately. Any data stored in the reception buffer of the device may get lost by this. During normal operation DTR_PGM is not queried. A change from the normal mode to other operating modes is therefore not possible while operating voltage is being applied.</p> <p>Transmitting data:</p> <p>The radio data to be transmitted is transparently transferred via the RS232 interface, while a RTS / CTS handshake is used for control. The delay between the CTS signal and the RTS signal can be set using the configuration software (see Table Configuration).</p> 

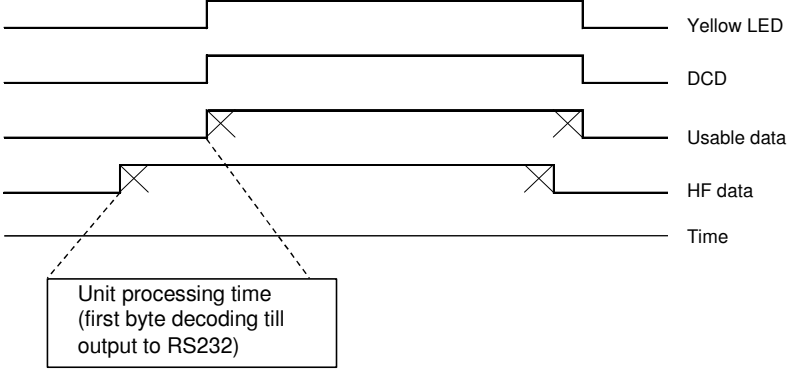
	<p>Receiving data:</p> <p>The DCD signal indicates the presence of valid data (usable data) on the radio interface (RF data) that is output, after a certain processing time, via RS-232.</p>  <p>The diagram shows five horizontal lines representing signals over time. From top to bottom: Yellow LED, DCD, Usable data, HF data, and Time. The Yellow LED signal is active during the period when Usable data is present. The DCD signal is active during the period when Usable data is present. The Usable data signal is active during the period when HF data is present. A callout box points to the period between the start of Usable data and the start of HF data, labeled 'Unit processing time (first byte decoding till output to RS232)'.</p>
<p>Configuration mode</p>	<p>Switching to this operating mode:</p> <ul style="list-style-type: none"> - When operating voltage is applied - DTR_PGM = VCC <p>Indication:</p> <ul style="list-style-type: none"> - green PWR LED flashes <p>RS-232 interface:</p> <ul style="list-style-type: none"> - RS232, 4.800 baud, 8N1 - no handshake <p>Mode of operation:</p> <p>In configuration mode the device communicates with a connected PC and the configuration software (see Configuration Table).</p>

Configuration

Using the inputs CS0 to CS2 it is possible to select eight available presets for frequency and transmission power (channels). In normal operation the channel is switched during reception. If a change of level CS0 to CS2 is made during transmission, the channel is switched immediately after completing the transmission operation upon return to the reception mode.

Channel	CS2	CS1	CS0
1	0	0	0
2	0	0	open
3	0	open	0
4	0	open	open
5	open	0	0
6	open	0	open
7	open	open	0
8	open	open	open

The **E205** is configured by means of a PC software (Windows). The RS-232 interface of the PC and the **E205** are thereby connected by a special cable which is available as an accessory (see "Connecting cables")

The installation of the configuration software is done by copying the files "E205config.exe" and "E205config.ini" to a suitable directory of a Windows PC.

"File" menu

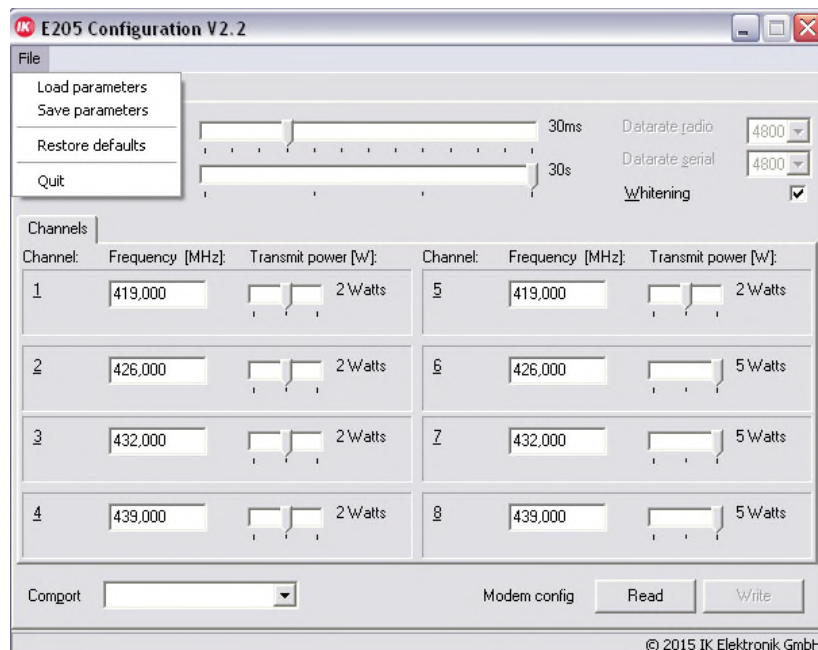

Command	Function
Load parameters	Loads previously with "Save parameters" saved settings from a file
Save parameters	Saves settings to a file
Restore defaults	Loads presets from the "E205config.ini" file
Quit	Quits the program

“Parameters” tab

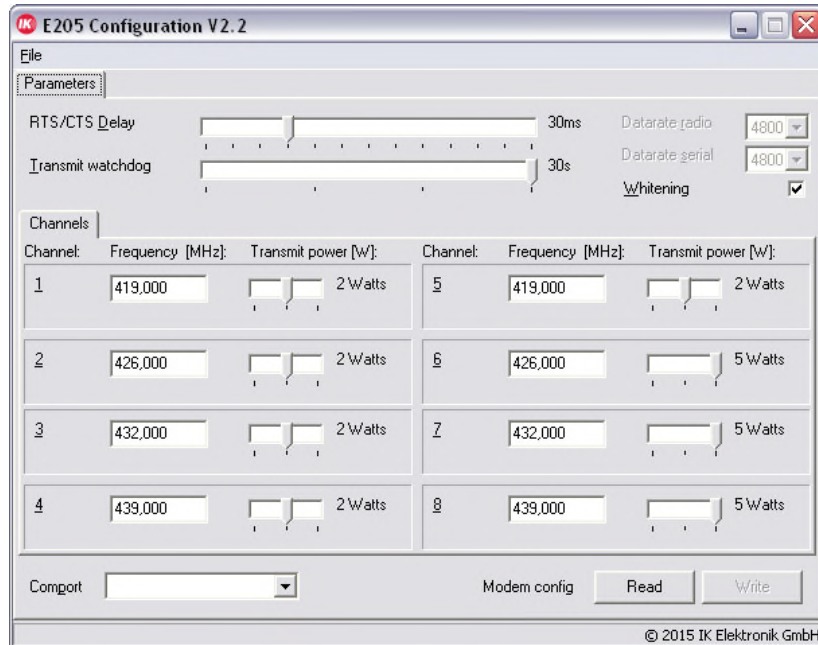

Item	Function
RTS/CTS Delay	Sets the delay time between RTS and CTS (see Tables Operating modes and Features)
Transmit watchdog	Maximum transmission time. Once the set time has expired, the E205 automatically switches from transmission to reception mode. Set "0" to disable this function (see Features Table)
Datarate radio	Displays the fixed data rate for radio transmission
Datarate serial	Displays the fixed data rate for the RS-232 interface
Whitening	Activates a simple additional coding for the radio signal (no encryption)
Channels	Used for setting the frequency and transmission power for the channels adjustable by CS0, CS1 and CS2
Comport	Used for selecting the serial interface of the PC for communication with E205

Conformity

E205 has been tested by applying the following standards. For the use a separate frequency assignment (license) is required. Please contact the relevant national frequency authority.

EMC	EN 301 489-1 V1.9.2 EN 301 489-5 V1.3.1
RES	EN 300 113-1 V1.7.1 EN 300 113-2 V1.5.1
Safety	EN 60950-1:2006+A11:2009+A1:2010+A12:2011+A2:2013
EMF	EN 62311:2008
RoHS 2	EN 50581:2012

Safety Instructions

Installation, commissioning, parameterization, maintenance and service of **E205** must be carried out by authorized specialists.

The product is intended for commercial use only.

Unauthorized opening, conversion and / or modification of the product are not permitted and will void the warranty.

The product may be used only in dry, closed rooms. It must not get damp or wet or get in contact with high dust concentrations or aggressive chemicals. Otherwise there is a risk of destruction or a functional failure.

When installing or handling the unit, please note that it may become hot in operation.

E205 has sharp corners and edges, especially in the area of the heat sink. There is a risk of injury.

Electrical and electronic products contain many valuable materials. Therefore, dispose of the product at the end of its service life in accordance with applicable laws and regulations.

Any damages caused by failure to observe this data sheet will invalidate the warranty claim. We assume no liability for consequential damages.

We assume no liability for material or personal damages caused by improper handling or failure to observe the safety instructions. In such cases, the warranty becomes void.

Scope of Delivery

- **E205** Long Range Wireless Modem
- Data Sheet and Software documentation in electronic form
- Configuration software

Optionally available:

- Adapter Box for connecting the **E205** to a PC for configuration, also suitable for data transmission to a connected device

Not included in the scope of delivery:

- External antenna
- Power supply unit

The most current data sheets, software and documentation can be found at:

www.ik-elektronik.com/blog_e205

Manufacturer

IK Elektronik GmbH
Friedrichsgrüner Straße 11-13
D-08262 Muldenhammer, Germany

Tel. (+49) 37465 4092-0
Fax (+49) 37465 4092-100
www.ik-elektronik.de

All information contained in this data sheet has been prepared with utmost care. However, IK Elektronik cannot be made liable for damages related to the use of the content of this document.

IK Elektronik reserves the right to make changes in this document, the scope of delivery and technical modifications to the described product without special notice.

Revisions

Rev.	Date	Modification	Prepared	Checked	Approved
V 1.0	2024-01-29	Revision of current consumption 2W transmission	KEK	JRI	JEK
V 1.0	2017-04-07	Revision, Specification of absolute maximum ratings	JRI	MAH	JEK
V 1.0	2015-12-17	Revision, Specification of Reliability, standards added	MAH	JRI	JEK
V 1.0	2015-08-25	Revision, translation	MAH	JRI	JEK
V 1.0	2015-08-25	First release	JEK / JRI	JRI	JEK